



## Vibratory Tampers

# SRV 590 / SRV 620 / SRV 660

# Vibratory tampers from Weber MT: quality that will get you ahead

Excellent compaction results, exemplary operating comfort and rugged design are the essential requirements vibratory tampers must meet. Customers looking to purchase a premium quality tamper need to look no further than the powerful machines being offered by Weber MT.

Regardless of the job requirements Weber MT has a vibratory tamper to meet the customers needs, from earth compaction in sewage and trench construction, a of backfill, shoulder compaction or patching repairs in road construction to their use in gardening and landscaping.



Vibratory tampers with 4-stroke gasoline engine



SRV 590



SRV 620



SRV 660

with Honda GXR 120

with Honda GX 100

with Subaru EH 12

## Advantages of Weber MT's tampers

- ▶ High tamping outputs.
- ▶ Components optimally matched to each other.
- ▶ Maximum reliability due to the use of high-quality materials.
- ▶ High wear resistance thanks to special material treatment processes such as the ceramic-like coating applied on the guide cylinder.
- ▶ Low maintenance efforts.
- ▶ 2 year warranty.

**Vibratory tampers from Weber MT:  
secure quality for you and your customers.**

The 4 stroke gasoline engines in the SRV vibratory tampers excel by their outstanding starting behaviour and their low exhaust emission. A special fuel tank with a capacity of 3 l ensures long running times. In addition: integrated fuel filter, tank cap with ventilation and deaeration and possibility to hang up the tank cap during refueling.

A powerful, multi-stage air filtration system guarantees maximum operating reliability and safety.

**Maximum operating safety.**

Multi-stage air filtration system with cyclone pre-cleaner<sup>1</sup>, pre-filter<sup>2</sup> and main filter<sup>3</sup>. The air filter of the engine manufacturer is an additional security.

*Photo: SRV 620*



**Additional features**

- ▶ A durable tamping system with an active oil lubrication, providing reliable oil support to all components in the crankcase.
- ▶ Damage to the tamping system is being prevented through block impact protection.
- ▶ The highly efficient air filtration system with cyclone pre-cleaner protects the engine against dirt.
- ▶ Low engine oil warning (SRV 590/620). During start-up, the electronics reliably measures the engine oil level. An LED lights up to indicate a lack of engine oil.
- ▶ Easy transport through carrying handles and rolls.
- ▶ High operating comfort through minimized hand-arm vibrations.
- ▶ Optional extras: hour meter, wheel kit.

## Technical data

Typ		SRV 590	SRV 620	SRV 660
Operating weight CECE	kg (lbs)	62 (136)	66 (145)	75 (165)
Shoe width	mm (in.)	280 (11)	280 (11)	280 (11)
Percussion	per min.	700	700	670
Stroke	mm (in.)	64 (2.5)	65(2.6)	70 (2.8)
Engine manufacturer		Honda GXR 120	Honda GX 100	Subaru EH 12
Engine type		4-stroke gasoline	4-stroke gasoline	4-stroke gasoline
Engine output max.	kW (HP)	2.8 (3.8)	2.1 (2.9)	2.6 (3.6)
Power output at operating speed	kW (HP) at r.p.m.	2.6 (3.6) at 4,100 rpm	1.8 (2.5) at 4,100	2.3 (3.1) at 3,600

We reserve the right to alter specifications.

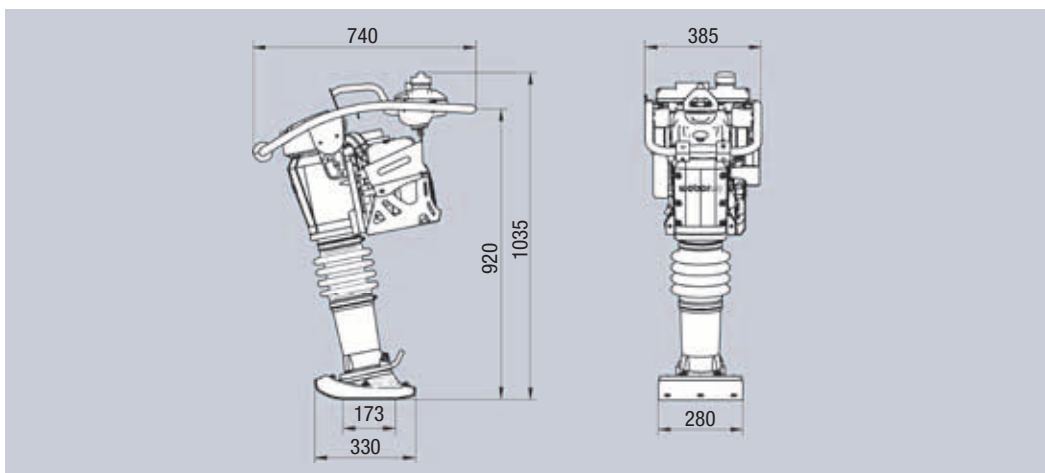
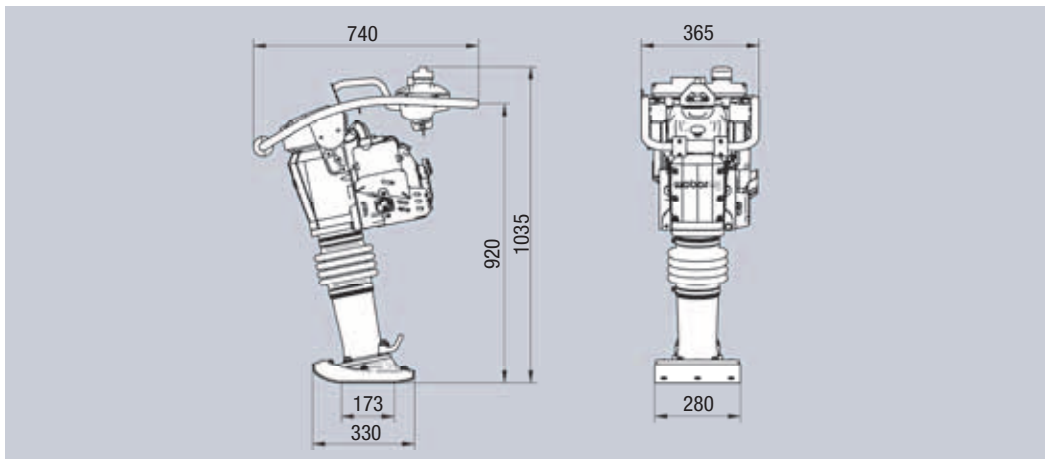
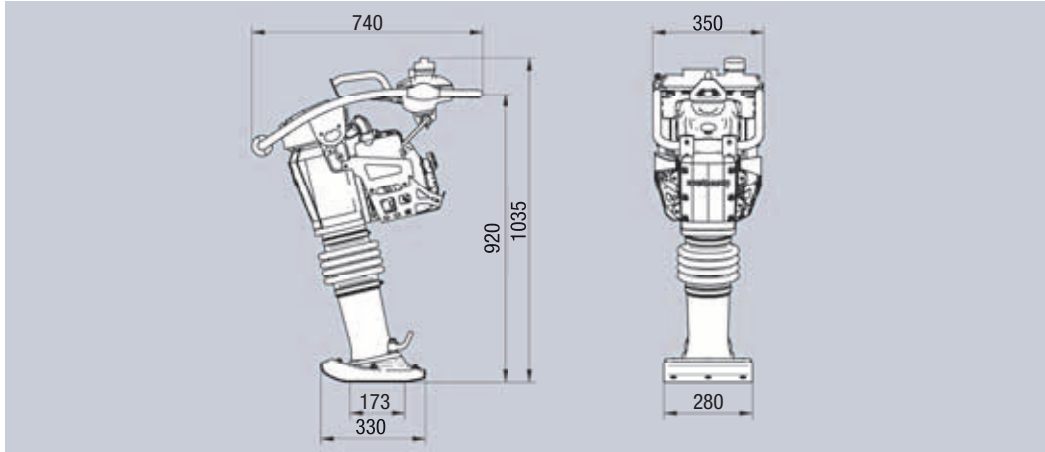

Dimensions in mm.